

## STARFIBER 150/300 P

### LONG PULSE FIBER LASER

ROFIN's pulsed fiber laser StarFiber 150/300 P combines high pulse energy and peak power with high beam quality and is characterized by high electrical efficiency, low maintenance and compact design. It is the economic solution for demanding cutting, welding and drilling applications. The StarFiber 150 P is available as a multimode or singlemode source – the StarFiber 300 P comes as a multimode source. These air-cooled lasers exceed the requirements of flexible industrial production and their modern industrial interface makes them easy to integrate.

#### Features

- High peak power (1.5 kW, 3.0 kW) combined with high pulse energy (15 J / 30 J) and high beam quality. Thus cutting, drilling and scribing becomes faster, more precise. It also cuts thick, hard and brittle materials like sapphire, PCD or ceramics in a very high quality
- High peak power (1.5 kW, 3.0 kW) for welding of highly reflective materials
- High aspect ratio single shot and percussion drilling at high productivity
- Scribing of brittle materials
- Wide range of ROFIN application packages for fine cutting, welding and drilling



# STARFIBER 150/300 P

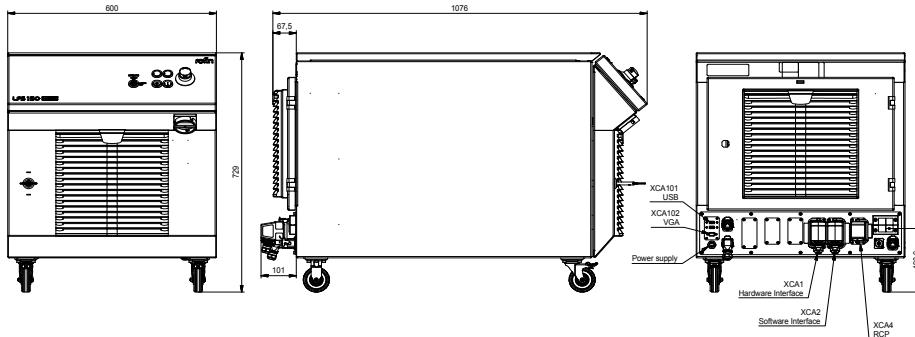

## Specifications

Pulsed fiber laser		StarFiber 150 P	StarFiber 300 P
Wavelength	nm	1070	
Output power max.	W	150	300
Pulse length max.	ms	50	
Pulse energy max.	J	15	30
Pulse repetition rate max.	kHz	50	
Pulse power	kW	1.5	3
Average power cw, max.	W	250	300
Long-term stability		± 1%	
Red aiming beam	mW	0.5	
Fiber type		single-mode (SM) or multimode (MM)	multimode (MM)
Fiber length		3.7 m (SM) or 4.7 m (MM), non-detachable	
Minimum bending radius	mm	min. 50	
<b>Environmental and Electrical Operating Conditions</b>			
Supply voltage		100 - 240 V, 50/60 Hz, 1P + N + PE	
Power consumption max.	W	1500	1500
Cooling		air-cooled	
Weight laser source in housing	kg	80	90
Dimensions laser source in housing	mm (L x W x H)	1076 x 600 x 729	
Dimensions OEM version	mm (L x W x H)	(19" x 8 HU x 610 mm)	(19" x 9 HU x 610 mm)
<b>Options</b>			
RCP operate panel; RTI control interface; galvo interface			
Compatible with FLBK 60, Double/Triple FLBK, FLBK SC, LLDROP, Scanner			
19" rack mount units for integration (OEM version)			

ROFIN-BAASEL Lasertech GmbH & Co.KG  
 Zeppelinstraße 10-12  
 82205 Gilching  
 Phone: +49 8105 3965-0  
 Fax: +49 8105 3965-4159  
 E-mail: sales-micro@rofin.de

ROFIN-SINAR Laser GmbH  
 Berzeliusstr. 87 22113 Hamburg  
 Phone: +49-(0)40-7 33 63-0  
 Fax: +49-(0)40-7 33 63 4100  
 E-mail: info-macro@rofin.de

ROFIN-SINAR Laser GmbH  
 Dieselstr. 15 85232 Bergkirchen  
 Tel.: +49-(0)81 31-704-0  
 Fax: +49-(0)81 31-704 4100  
 E-mail: info-marking@rofin.de

[WWW.ROFIN.COM](http://WWW.ROFIN.COM)

Benelux: Phone: +31 78 69310-37  
 E-mail: info@rofin-baasel.nl

CA: Phone: +1 905 607-0400  
 E-mail: info-canada@rofin-inc.com

CH: Phone: +41 32 322-1010  
 E-mail: info@rofin-lasag.ch

CN: Phone: +86 21 68552216  
 E-mail: info@rofin-baasel.com.cn

ES/PT: Phone: +34 93 4770-644  
 E-mail: info@rofin-es.com

F: Phone: +33 1 6911-3636  
 E-mail: info@rofin.fr

IN: Phone: +91 22 276125-1  
 E-mail: info@rofin.in

IT: Phone: +39 039 2729-1  
 E-mail: info@rofin.it

JP: Phone: +81 46 229-8655  
 E-mail: info@rofin-baasel.co.jp

KR: Phone: +82 2 837-1750  
 E-mail: info@rofin.co.kr

SG: Phone: +65 6482-1091  
 E-mail: reception@rofin-baasel.com.sg

TW: Phone: +886 2 2790-1300  
 E-mail: info@rofin-baasel.com.tw

UK: Phone: +44 1327 701-100  
 E-mail: sales@rofin-baasel.co.uk

US: Phone: +1 734 455-5400  
 E-mail: info@rofin-inc.com

Find further representatives and partners on: [www.rofin.com/worldwide](http://www.rofin.com/worldwide)



AVOID LASER RADIATION  
 AVOID EYE OR SKIN EXPOSURE  
 TO DIRECT OR SCATTERED  
 RADIATION  
 CLASS I LASER PRODUCT