



## LASER MARKING

Superior solutions for a wide range of applications



## ROFIN – LASERS FOR INDUSTRIAL MATERIAL PROCESSING

### Laser marking – fast, flexible and durable

ROFIN is a global leader in developing and manufacturing of industrial lasers and laser-based products for material processing applications. With a variety of CO<sub>2</sub>, rod, disc, fiber and diode lasers, ROFIN offers the widest and most powerful product range worldwide and combines profound experience in laser manufacturing with in-depth application expertise. Besides plain laser sources, ROFIN offers complete solutions for a wide range of material processing applications.

Laser marking is a fast and flexible process for product identification. Compared with other marking technologies such as inkjet printing and mechanical marking, laser marking has a number of advantages. It offers very high processing speeds, low operational costs and consistent high quality and durable results.



To learn more about our complete product range please visit [www.rofin.com](http://www.rofin.com)



## LASER MARKERS ALL-IN-ONE MARKING SOLUTIONS

Our lasers provide excellent marking quality on almost any material.

### PowerLine E Air 10/25 – All air-cooled laser marker with low operating costs

The PowerLine E Air 10 is an end-pumped solid-state laser, which is completely air-cooled. The operating costs of the system are low due to reduced energy consumption. Its efficient cooling technology makes it almost maintenance-free. The PowerLine E Air 25 provides best marking results even in case of dusty, oily or oxidized parts.

### PowerLine F 20/20 Varia/30/50/100 – Fiber technology with compact design

The PowerLine F lasers are diode-pumped, q-switched fiber lasers. They offer attractive total operating cost, high diode life and require only minimum maintenance. The space-efficient design of the PowerLine F series facilitates integration into existing production environments. The modular design allows for on-site service and increases availability.

Class 1 laser marking stations are ready-to-use solutions. Various options, fixed and selectable laser sources allow for exact adaptation to every marking task.

### Easy Mark

With a footprint of just 60x60 cm, the EasyMark is one of the most compact laser marking devices on the market. Marking tasks on metallic surfaces and plastics are handled effortlessly and with perfect results. The laser marker operates with a conventional household power source and requires no external cooling.

### CombiLine Basic

The CombiLine Basic offers efficient, high quality laser marking at a very attractive price. The system comes as a standing workstation with a large working chamber, an integrated laser marker and smart operation technology. It is optionally available with a rotary indexing table.

### CombiLine Advanced

Based on ROFIN's many years of experience in manufacturing of superior laser technology, the CombiLine Advanced offers reliable 24/7 operation. The robust worktable even carries large and heavy workpieces of up to 100 kg (model WT). The system is optionally available with a rotary indexing table.



## POWERLINE E AIR 10/25

### Completely air-cooled laser markers

Each component of the PowerLine E Air 10 /25 laser markers is efficiently air-cooled. The operating costs of the system are low due to reduced energy consumption and use of advanced air-cooling technology. In order to perfectly meet specific application requirements, the PowerLine E Air series laser markers are available in two different power ranges. High quality markings with alphanumerics, graphics, grayscale pictures, barcodes and matrix codes on various materials are carried out within short cycle times. In order to obtain best marking results on certain metals and plastics, the PowerLine E series is also available with water-air cooling and wavelengths of 1064 nm, 532 nm and 355 nm. Double head configurations with beam splitter and beam switch offer benefits when large marking fields or minimum process times are required. PC and supply components are housed in standard 19" modules. The compact laser head and the supply and control units can be integrated in customer-specific or ROFIN-supplied laser workstations.

#### YOUR BENEFITS

- low operating costs due to air cooling technology
- 19" components, compact dimensions
- different power ranges
- doubleheader configurations available

## POWERLINE F 20/20 VARIA/30/50/100

### Minimum maintenance

The PowerLine F series comprises innovative fiber lasers with different power ranges. The F 20 and F 30 systems deliver 1 mJ pulse energy with a fast turn-on time and high peak power over a wide range of repetition rates. The PowerLine F 20 Varia's adjustable pulse length provides perfect results even with challenging applications (e.g. corrosion-free marking). With its single-mode beam quality, the fiber laser will produce ultra-fine, crisp marks every time.

The PowerLine F 50 and F 100 are operated in pulse mode at frequencies up to 200 kHz. The emitted average laser power can be set using the fiber amplifier. Therefore those sources are perfectly suitable for high-speed marking.

#### YOUR BENEFITS

- low total operating costs
- different power ranges
- doubleheader configurations available
- completely air-cooled





View with door opened



Model with detachable side walls

## EASYMARK

### The compact and versatile marking system

The EasyMark series is one of the most compact laser marking systems on the market. With its innovative and flexible housing it can be perfectly customized to individual applications - as well as integrated into production lines as a class 4 laser system. The supply and control units and the working chamber are designed as separate modules. The EasyMark is your laser marking solution for various production environments (semi and fully automated production), a wide range of applications and most different materials.

#### YOUR BENEFITS

- integrable into production lines
- integrated air-cooling
- low maintenance and service costs
- easy operation due to graphical user interface



Engraving

Marking of medium lot sizes

#### OPTIONS

- rotation axis
- marking field 180 x 180 mm
- various camera viewing systems
- exhaust unit with remote control
- automatic door

**OPTIONS**

- rotation as well as linear axes (WT)
- swivelling unit for rotation axes (RT)
- exhaust unit
- foot switch
- barcode scanner
- T-grooved plate
- Smart View (WT)
- keyboard holder with keyboard
- signal lights



CombiLine Basic WT



CombiLine Basic RT

**COMBILINE BASIC**

**Laser workstation at an attractive price/performance ratio**

The CombiLine Basic offers efficient, high-quality laser marking at a very attractive price/performance ratio. The laser workstation accommodates air-cooled PowerLine F and PowerLine E Air laser markers in different power ranges. A regular single-phased power supply is all you need. The integrated computer controls all system components. Visual-Laser-Marker, a sophisticated, industry proven laser marking software, makes the definition of simple as well as complex marking layouts a breeze. All operating processes are controlled via a 15" touch screen. The wide, motorized door provides easy access to the spacious working chamber and offers enough room even for marking bulky workpieces. With a motorized z-axis, the marking head position can be precisely adjusted to varying workpiece heights.

**YOUR BENEFITS**

- |   |                            |
|---|----------------------------|
| ■ spacious working chamber with observations window | ■ space-saving design      |
| ■ programmable z-axis                               | ■ selectable laser markers |
| ■ smart operation technology                        | ■ low investment costs     |

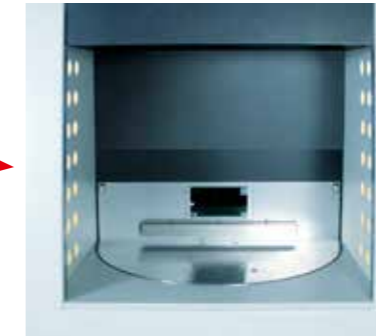

Rotary table version



Worktable version

## COMBILINE ADVANCED

Reliable 24/7 operation

With three program-controlled axes, the CombiLine Advanced easily marks even parts of complex geometry. Process visualization via a 15" TFT touchscreen monitor ensures maximum operating comfort. With all supply units accommodated in a compact housing, the workstation can be set up wherever optimum workflow and accessibility requires it. To ensure an optimal working height, the CombiLine Advanced is available for seated or standing operation.

### YOUR BENEFITS

- suitable for complex geometry and heavy workpieces
- worktable and rotary table versions available
- selectable laser sources
- seated workplace
- pneumatic door

### OPTIONS

- foot switch
- exhaust unit
- barcode scanner
- linear and rotation axes
- swivelling unit
- observation window
- vertical housing extension 200 mm
- longitudinal housing extension 400 mm
- robotics interface for front and side loading
- signal lights
- T-grooved plate (WT)
- extendable table (WT)

ROFIN offers you a comprehensively equipped laser application lab. Customer applications and lab studies can be carried out with the assistance of our experienced engineers. Virtually all of our marking systems are available for application trials. We will present you all possible laser concepts for consideration, with benefits and implications and together we will find the perfect solution for your individual laser task.

If your application strikes a new path in laser marking, we can call on our wide range of high-performance laser sources and combine them with efficient engineering and process technology to create a tailor-made complete system solution.

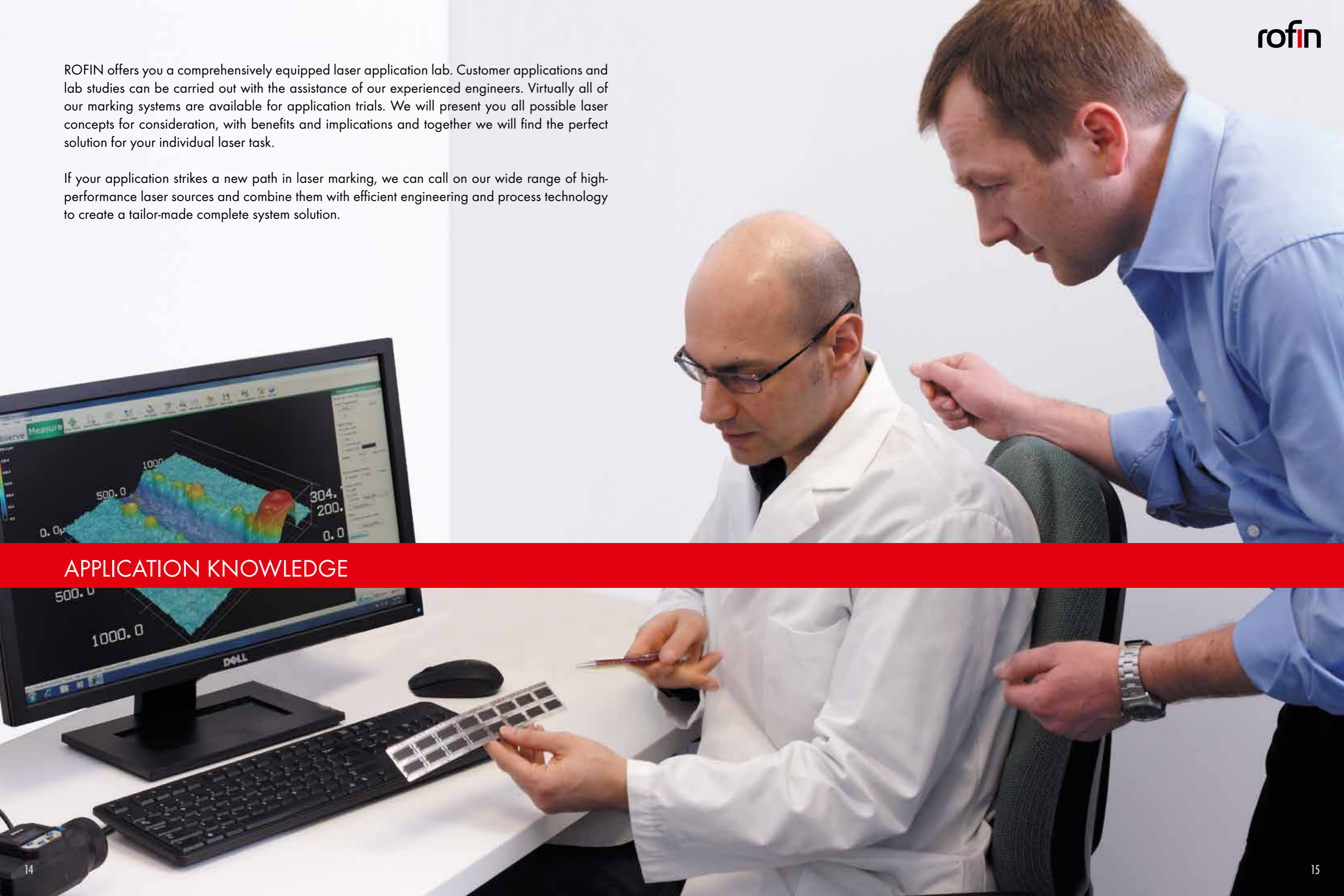

## APPLICATION KNOWLEDGE





VisualLaserMarker (VLM) is a sophisticated and flexible marking software used for all ROFIN lasers. Running on a standard PC environment, layout and transfer of the marking contents is a breeze. VLM is a “what you see is what you get” type software and offers the flexibility to be simple to use and yet powerful. VLM is able to fully integrate into any production software and is configured to handle all common communication methods. True type fonts are used directly, no need to convert to special fonts. In addition to several options such as CAD functions, VLM offers a wide range of marking functions, fonts and predefined laser parameter sets. The user-interface reflects ROFIN’s longtime laser marking expertise and is clearly arranged and can be operated easily.

VLM handles a wide variety of marking content e.g. matrix-codes, barcodes and serial numbers. Extremely small marks can be realized depending on the material. The sophisticated software controls marking on flat and curved surfaces and even marking-on-the-fly applications. Via an optical fast focussing module various workpiece heights can be processed quickly – travel time from upper to lower end position is just 15 ms.

Continuous, user-oriented development, individual solutions and customer support are the focus of our software work.

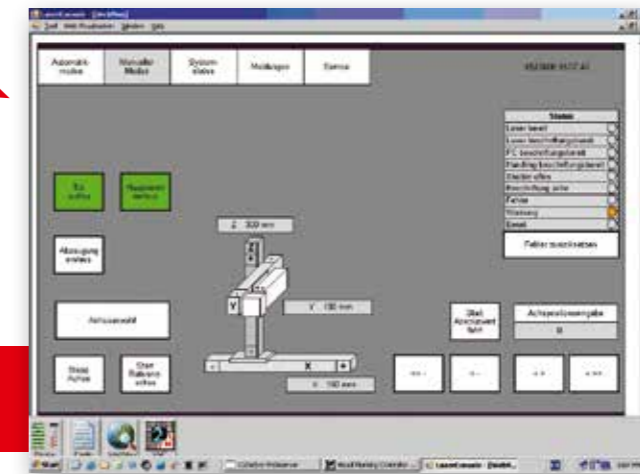

Laser workstation oriented visualization via web interface.

## VisualLaserMarker SOFTWARE –

Powerful and simple to use



Laser display and graphical user interface

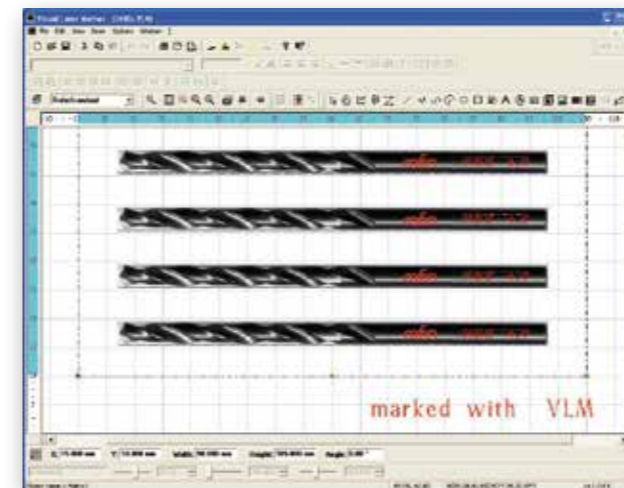

Row and column marking of workpieces.



ROFIN offers a solution specifically developed for fast high-quality on-the-fly marking of moving workpieces. Linear as well as rotational movement can be handled. In the latter case the marking is carried out tangentially on the surface shell without any distortions. Positioning and movement compensation data is processed in real-time. The software even handles speed changes during the marking process.

The VisualLaserMarker Software will help you to design the marking layout. It offers various possibilities for creating marking objects and workpieces and is extendable with VBScript macros. All laser markers have a wide range of interfaces, so even complex workflows or data integration is handled easily.



Screenshot marking on-the-fly

## LASER MARKING

Efficient on-the-fly marking of workpieces

### FEATURES AT A GLANCE

- short cycle times
- excellent marking results without visible overlaps or gaps
- available with any ROFIN laser marker
- wide application range



Marking of a continuously rotating workpiece



ROFINs software comes with an integrated module, which offers distortion-free parallel projection of marking contents onto free-form surfaces. Parallel projection ensures geometrically correct marking layout reproductions even on curved or irregular shaped surfaces. Dimensional variation or distortion are a matter of the past. The software incorporates a 3D correction field when preparing the data for the laser marking process.

Prior to this, the 3D correction field is generated with a 3D simulation, where the virtual marking field is placed within or above the visualized workpiece. The optionally available Fast Focusing Module (FFM) brings free form marking to perfection, particularly when large marking fields are required or pieces with bigger height variations have to be processed.

PERFECT LASER MARKING

Of free-form surfaces

Distortion-free marking of three-dimensional objects

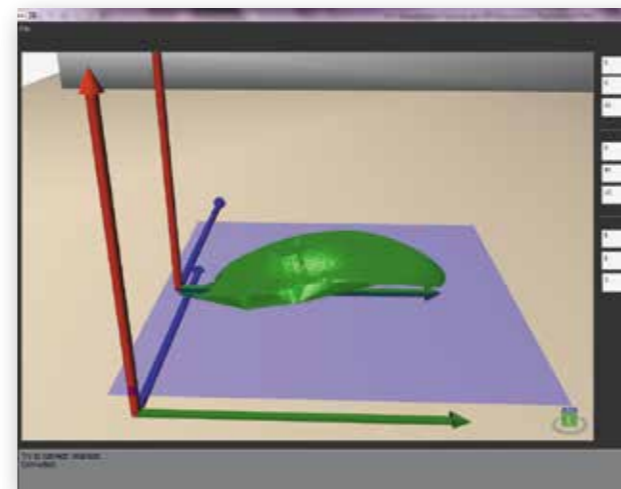

3D model positioning

- YOUR BENEFITS**
- 100% correct geometry reproduction
  - no dimensional variation or distortion
  - arbitrary free form surfaces are possible
  - fully automatic correction

- OPTIONS**
- Fast Focusing Module (FFM) for fast focal shift
  - perfectly even line widths within large marking fields
  - optimum marking quality within the entire marking area

**Additional sales & service subsidiaries:**

- ROFIN-BAASEL France | Lisses
- ROFIN-BAASEL Italiana | Monza
- ROFIN-BAASEL Espana | Barcelona, Arazuri
- ROFIN-BAASEL UK | Daventry
- ROFIN-BAASEL Benelux | Alblasterdam/NL, Brussels/BE
- ROFIN-BAASEL Swiss | Biel
- ROFIN-BAASEL Japan | Atsugi
- ROFIN-BAASEL Korea | Seoul
- ROFIN-BAASEL Taiwan | Taipei
- ROFIN-BAASEL China | Shanghai, Beijing, Shenzhen, Wuhan
- ROFIN BAASEL Laser India | Mumbai
- ROFIN-BAASEL, Inc. | Chandler/USA
- ROFIN-SINAR, Inc. | Buffalo Grove (ROFIN-LASAG Medical)/USA
- ROFIN-BAASEL Canada | Mississauga
- DILAS Diodelaser | Shanghai/China
- PRC Europe | Oudenaarde/Belgium
- WB-PRC Laser | Zorneding/Germany

- Production sites
- Additional sales & service subsidiaries
- Representatives

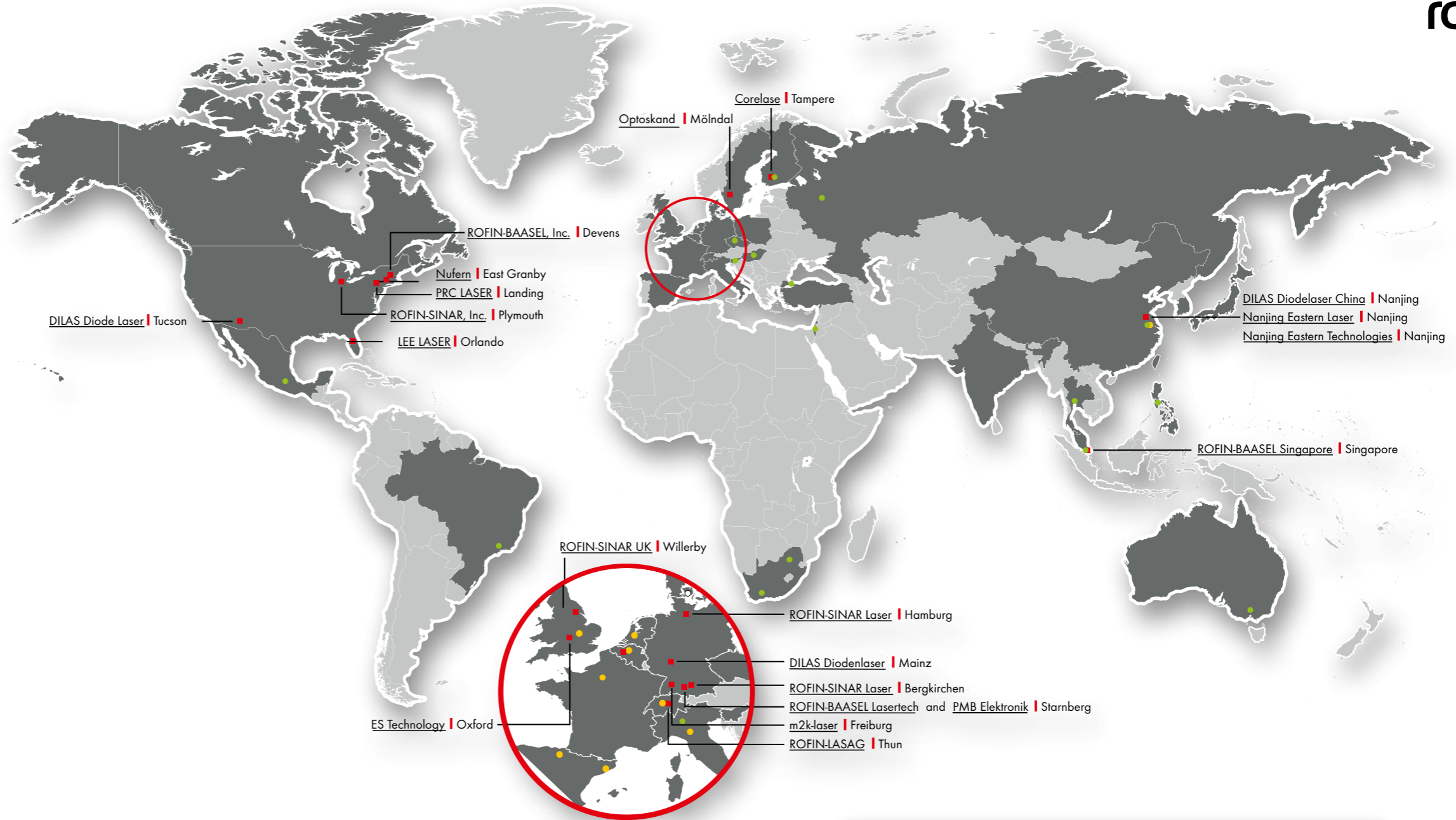

## SERVICE AND TRAINING

ROFIN optimized the design of its marking lasers for easy servicing. Maintenance work is reduced to a minimum. Just in case: ROFIN's worldwide service network is ready for support on-site when required.

We offer local spare parts centers with modern logistics. Our customers all over the world benefit from individual service agreements and hotline support.



## TECHNICAL DATA POWERLINE E AIR 10 AND 25

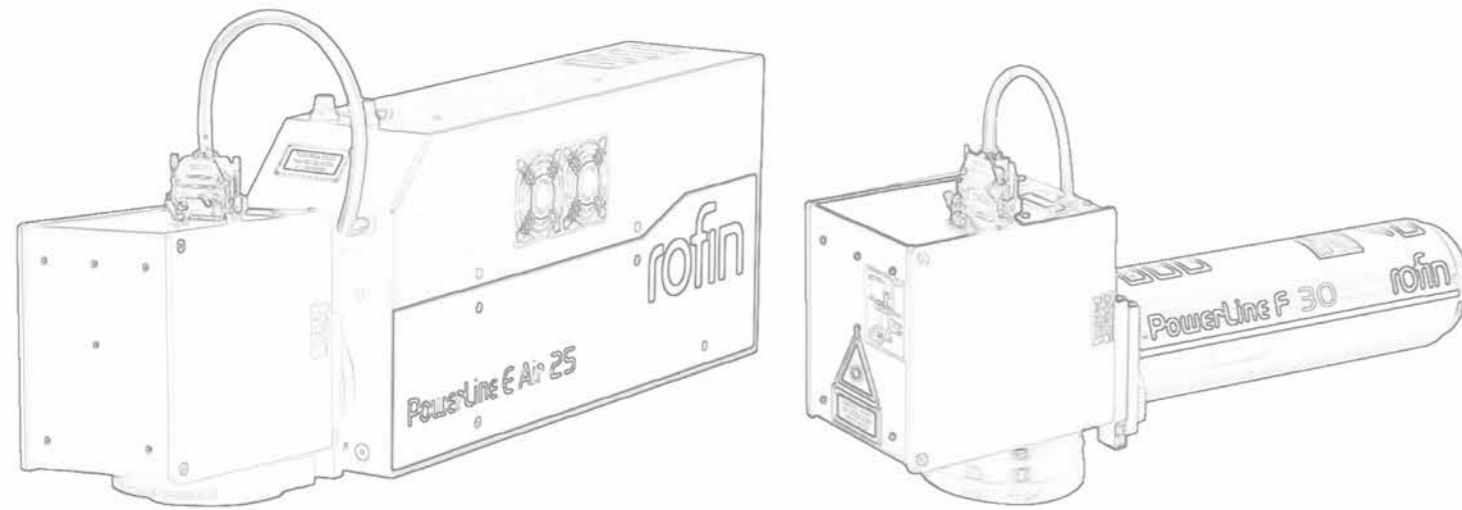

**Laser and galvo PowerLine E Air 10**

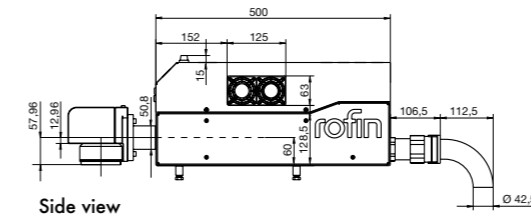

**Laser and galvo PowerLine E Air 25**

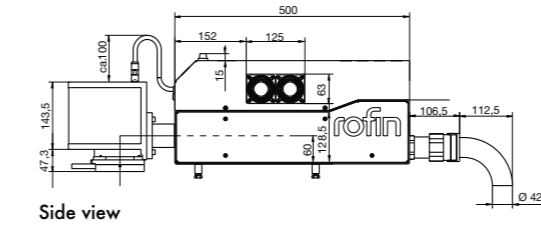

**Supply unit for PowerLine E Air 10/25 and PowerLine F 20/30**

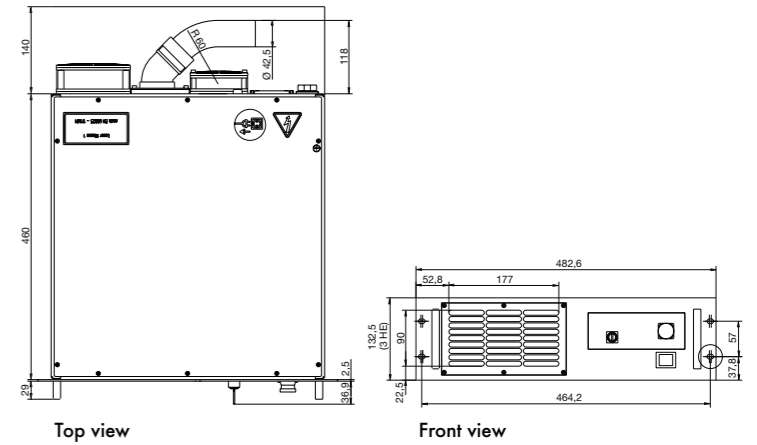

## LASER COMPARISON AT A GLANCE

### Laser head

Wavelength (nm):	1064
Pulse frequency (kHz):	0 - 200, cw as well
Laser dimensions (W x L x H, mm):	118 x 500 x 220
Laser weight (kg):	approx. 18
Ingress protection:	IP 54
Air flow (m <sup>3</sup> /h):	approx. 120

### Marking unit

Field size (mm):	120 x 120 (other size on request)
Ingress protection:	IP 54

### Supply unit and PC (19")

Supply unit dimensions (W x L x H, mm):	483 (19") x 460 x 3 rack units
Supply unit weight (kg):	approx. 28
PC dimensions (W x L x H, mm):	483 (19") x 479 x 2 rack units
Software:	Windows Embedded 2009, Windows Embedded Standard 7
Cooling:	integrated air cooling
Power supply:	120 - 240 VAC, +/-10% VAC, 50 - 60 Hz (E Air 10) 208 - 240 VAC, +/-10% VAC, 50 - 60 Hz (E Air 25)
Power consumption supply unit incl. PC(W):	500 (PowerLine E Air 10) 610 (PowerLine E Air 25)
Ingress protection:	IP 20
Operating temperature (°C):	15 - 35
Air flow 19" supply unit (m <sup>3</sup> /h):	approx. 250

## TECHNICAL DATA POWERLINE F 20, 20 VARIA AND 30

### PC PowerLine E Air 10/25 and PowerLine F 20/30

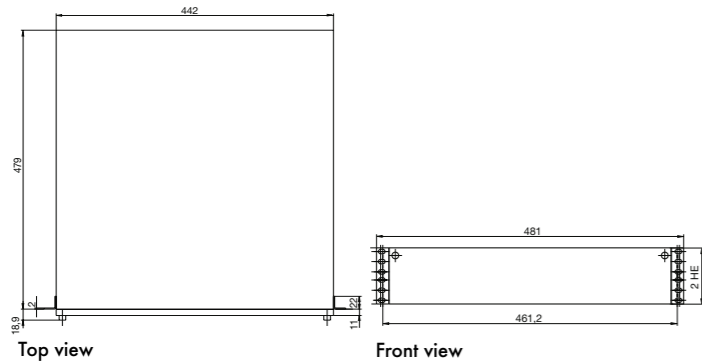

### Laser and galvo PowerLine F 20

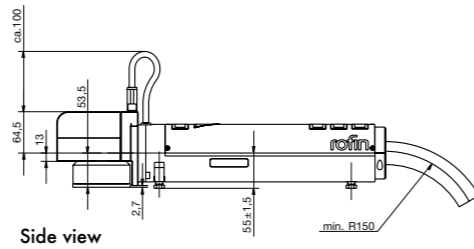

### Laser and galvo PowerLine F 30

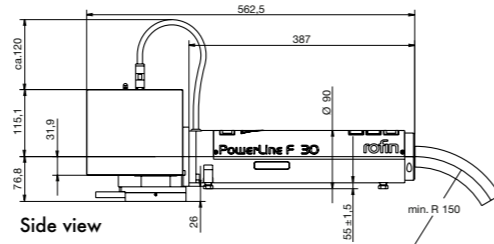

### Laser head

Wavelength, typ. (nm):	1064
Pulse frequency (kHz):	PowerLine F 20: 20 - 100 PowerLine F 20 Varia: 1.6 - 1000 PowerLine F 30: 30 - 100
Pulse width (ns):	PowerLine F 20 Varia: 4 - 200, adjustable
Laser dimensions (mm):	length 387, Ø 90 PowerLine F 20 Varia: length 594, Ø 100
Laser weight (kg):	PowerLine F 20: 5.5 / PowerLine F 30: 5.7 / PowerLine F 20 Varia: approx. 8.6
Ingress protection:	IP 54

### Marking unit

Field size (mm):	120 x 120
Ingress protection:	IP 54

### Supply unit and PC (19")

Supply unit dimensions (W x L x H, mm):	483 (19") x 460 x 3 rack units
Supply unit weight (kg):	23.5, PowerLine F 20 Varia: approx. 25
PC dimensions (W x L x H, mm):	483 (19") x 479 x 2 rack units
Software:	Windows Embedded 2009, Windows Embedded Standard 7
Cooling:	integrated air cooling
Power supply:	115 - 240 VAC, +/-10% VAC, 50/60 Hz
Power consumption supply unit incl. PC (W):	PowerLine F 20: approx. 330 PowerLine F 30: approx. 390 PowerLine F 20 Varia: approx. 350
Ingress protection:	IP 20
Operating temperature (°C):	15 - 35
Air flow 19" supply unit (m³/h):	approx. 130, approx. 170 by PowerLine F 20 Varia

## TECHNICAL DATA POWERLINE F 50 AND 100

### Laser and galvo PowerLine F 50/100

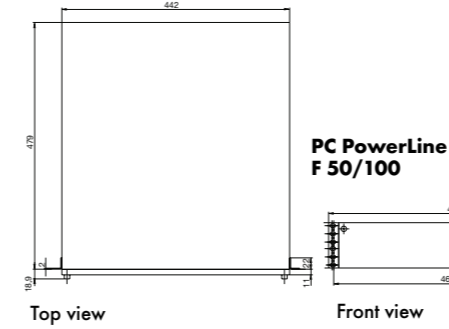
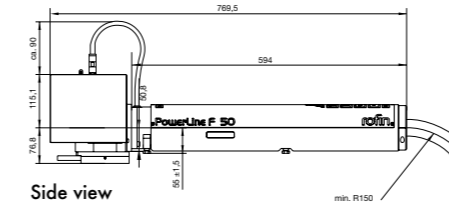

### Supply unit PowerLine F 50/100

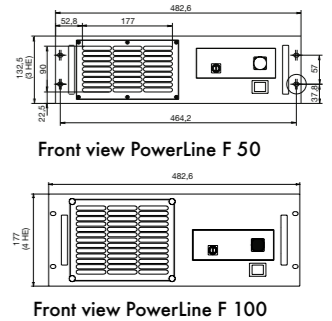
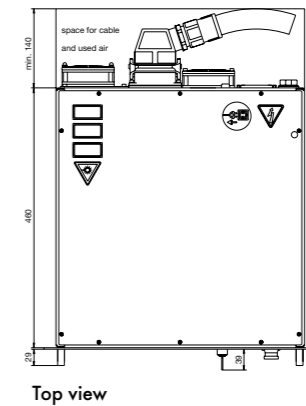

### Laser head

Wavelength, typ. (nm):	1064
Power class (W):	50/100
Pulse frequency (kHz):	F 50: 50 - 200 F 100: 5.1 - 200
Laser dimensions (mm):	length 594, Ø 100
Laser weight (kg):	approx. 8.6
Ingress protection:	IP 54

### Marking unit

Field size (mm):	120 x 120
Ingress protection:	IP 54

### Supply unit and PC (19")

Supply unit dimensions (W x L x H, mm):	19" x 460 x 3 rack units (F 50) 19" x 460 x 4 rack units (F 100)
Supply unit weight (kg):	approx. 28
PC dimensions (W x L x H, mm):	19" x 479 x 2 rack units
PC weight (kg):	10
Software:	Windows Embedded 2009, Windows Embedded Standard 7
Power supply:	115 - 240 VAC, +/-10% VAC, 50/60Hz
Power consumption supply unit incl. PC (W):	approx. 470 (F 50). approx. 570 (F 100)
Ingress protection:	IP 20
Operating temperature (°C):	15 - 35
Air flow 19" supply unit (m³/h):	approx. 130 (F50) approx. 170 (F 100)

**TECHNICAL DATA EASYMARK**

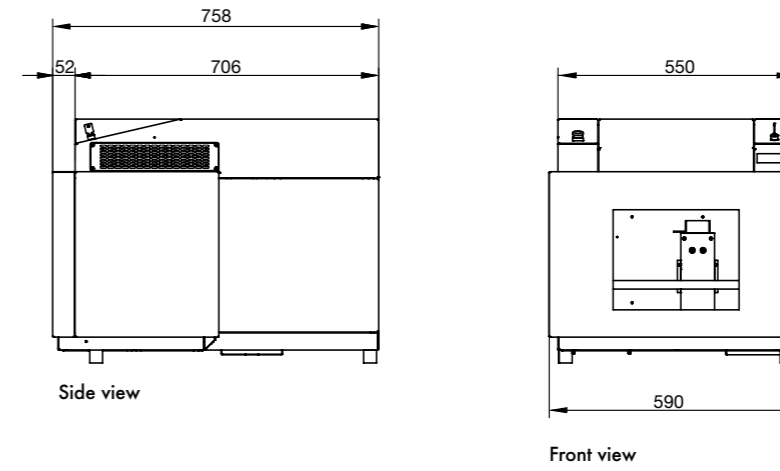
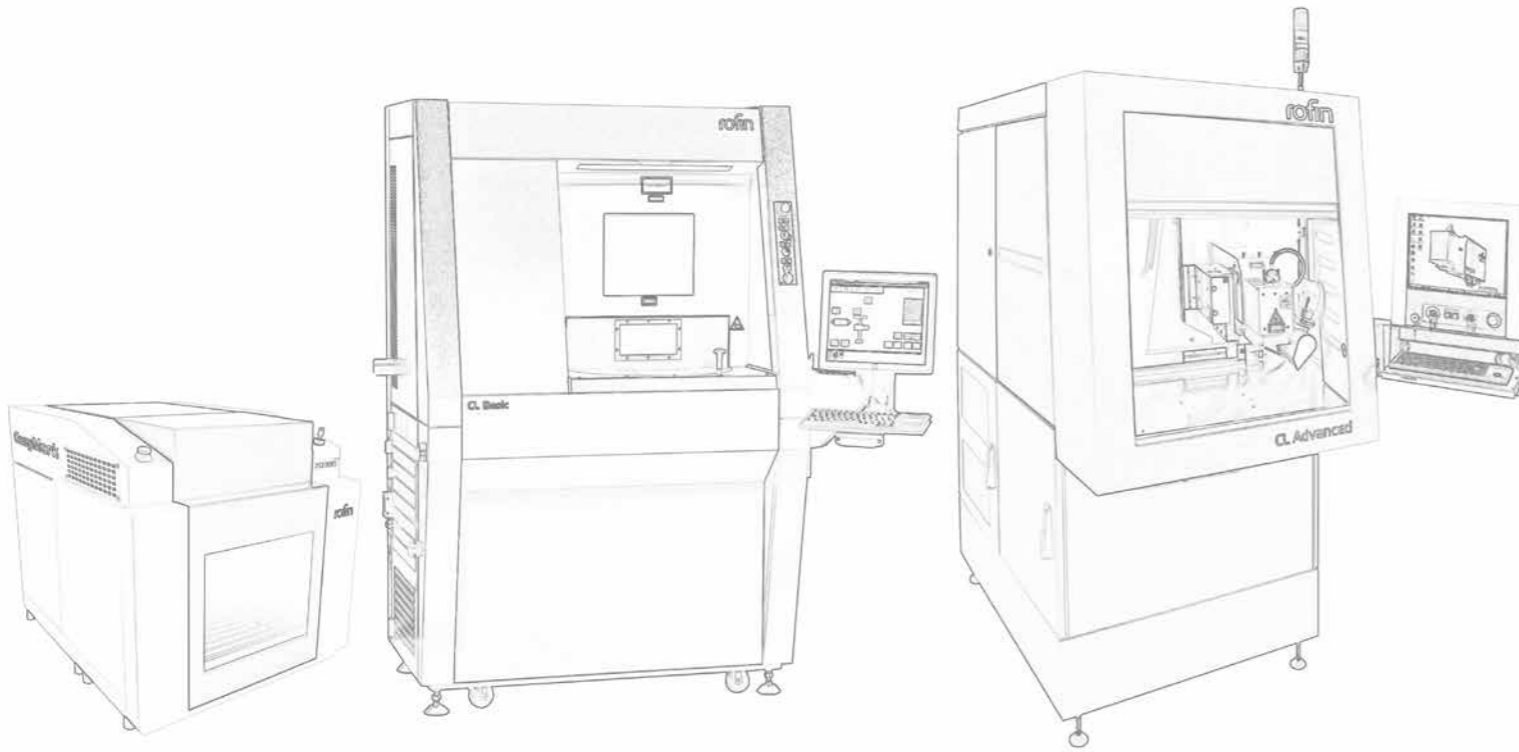

**LASER WORKSTATION COMPARISON AT A GLANCE**

**EasyMark**

Marking laser:	PowerLine E Air 10 PowerLine F 20/30/50
----------------	--

**Supply and marking unit**

Dimensions (W x D x H, mm):	590 x 760 x 570 (160 mm objective) 590 x 760 x 690 (254 mm objective)
Machine weight (kg):	80
Max. workpiece dimension (W x D x H, mm):	300 x 120 x 200
Max. workpiece weight incl. fixture (kg):	max. 10
Marking field size (mm):	120 x 120 (160 mm objective) 180 x 180 (254 mm objective)
z-axis travel (mm):	120
Door:	manual
Lateral feeding of the workpiece:	optional
Power supply:	100 - 240 VAC, +/- 10 %, 50/60 Hz
Max. power consumption (W):	< 600
Cooling:	integrated air cooling
Color:	RAL 9016 / RAL 7016 / RAL 3020

## TECHNICAL DATA COMBILINE BASIC

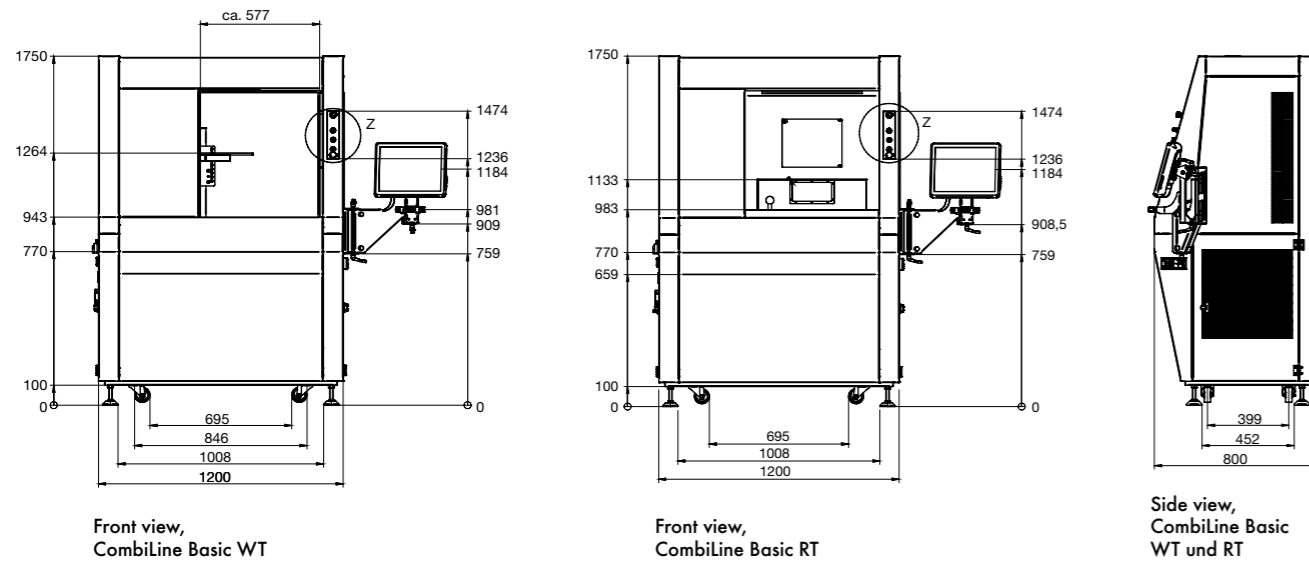

	CombiLine Basic WT	CombiLine Basic RT
Marking laser:	PowerLine E Air PowerLine F	PowerLine E PowerLine F
Dimensions (W x D x H, mm):	1200 x 800 x 1750 (without TFT-Touch) 1750 x 800 x 1750 (with TFT-Touch)	1200 x 800 x 1750 (without TFT-Touch) 1750 x 800 x 1750 (with TFT-Touch)
Machine weight (kg):	approx. 380 *	approx. 430 *
Max. workpiece dimension (W x D x H, mm):	620 x 450 x 290*	300 x 200 x 145*
Max. workpiece weight incl. fixture (kg):	20	5 each side
Marking field size (mm):	120 x 120 180 x 180 240 x 240	120 x 120 180 x 180 240 x 240
z-axis travel (mm):	max. 300*	max. 300*
Door:	automated	no door, height of partition panel 150 mm, rotary disk Ø 540 mm
Power supply:	230 VAC +/-10%, 50-60 Hz	230 VAC +/-10%, 50-60 Hz
Max. power consumption (W):	< 600	< 600
Color:	RAL 9016 / RAL 7016	RAL 9016 / RAL 7016

\* dependent on selected configuration

## TECHNICAL DATA COMBILINE ADVANCED

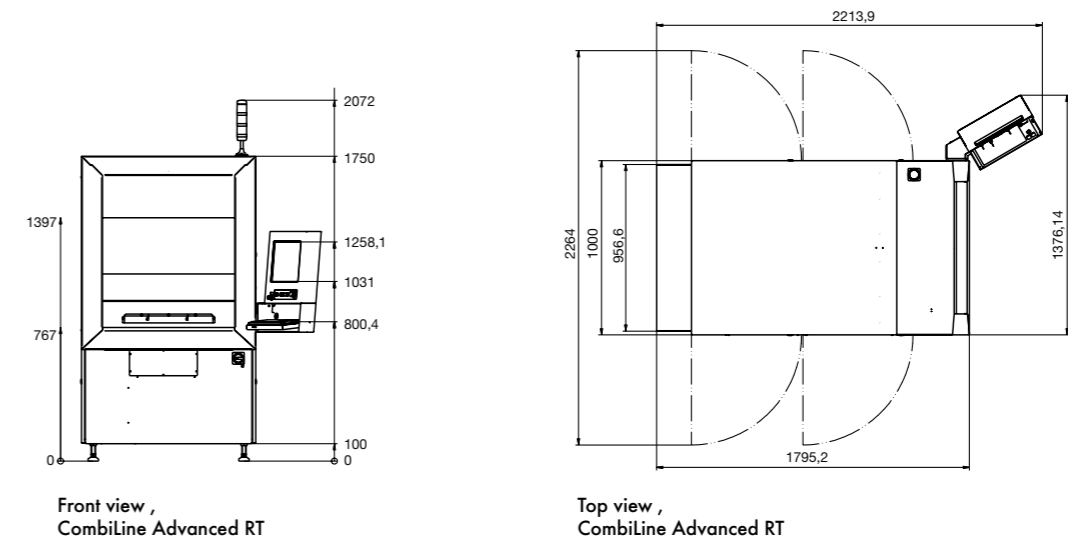

	CombiLine Advanced WT	CombiLine Advanced RT
Marking laser:	PowerLine E PowerLine E Air PowerLine F	PowerLine E PowerLine E Air PowerLine F
Dimensions (W x D x H, mm):	1376 x 2013 x 1750 (seated operation) 1376 x 2013 x 1900 (standing operation)	1376 x 2214 x 1750 (seated operation) 1376 x 2214 x 1900 (standing operation)
Machine weight (kg):	approx. 800 *	approx. 490 *
Max. workpiece dimension (W x D x H, mm):	700 x 550 x 500*	400 x 300 x 295 (RT)
Max. workpiece weight incl. fixture (kg):	100	10 each side
Working height (mm):	750, (standing operation: 900)	750, (standing operation: 900)
Marking field size (mm):	120 x 120	120 x 120
Axis travel (mm):	z: max 300*	z: max 300*
Rotary table diameter (mm):	not applicable	800
Rotation time of rotary table (s):	not applicable	2.4
Door:	pneumatic door	not applicable
Power supply:	230 / 400 V (+/- 10%); 3P; N; PE; 50/60 Hz;	230 / 400 V (+/- 10%); 3P; N; PE; 50/60 Hz;
Max. power consumption (W):	approx. 800 *	approx. 800 *
Compressed air (bar):	6	not applicable
Color:	RAL 9016 / RAL 7016	RAL 9016 / RAL 7016

\* dependent on selected configuration



**LASER MARKING**

ROFIN-SINAR Laser GmbH  
 Dieselstr. 15  
 85232 Bergkirchen  
 Germany  
 Phone: +49(0)8131-704-0  
 Fax: +49(0)8131-704-4100  
 E-mail: info@rofin-muc.de

**LASER MICRO**

ROFIN-BAASEL Lasertech GmbH & Co. KG  
 Petersbrunner Str. 1b  
 82319 Starnberg  
 Germany  
 Phone: +49(0)8151-776-0  
 Fax: +49(0)8151-776-4159  
 E-mail: sales@baasel.de

**LASER MACRO**

ROFIN-SINAR Laser GmbH  
 Berzeliusstraße 87  
 22113 Hamburg  
 Germany  
 Phone: +49(0)40-733-63-0  
 Fax: +49(0)40-733-63-4100  
 E-mail: info@rofin-ham.de

[WWW.ROFIN.COM](http://WWW.ROFIN.COM)

More brochures of ROFIN:



- DE/AT:** Phone +49-(0)831-704-0  
E-mail: info@rofin.de
- Benelux:** Phone +31-(0)78-69310-37  
E-mail: info@rofin-baasel.nl
- CA:** Phone +1-905-607-0400  
E-mail: info-canada@rofin-inc.com
- CH:** Phone +41-(0)32-3221010  
E-mail: info@rofin-baasel.ch
- CN:** Phone +86-21-6855-2216  
E-mail: info@rofin-baasel.com.cn
- ES/PT:** Phone +34-948-324-600  
E-mail: info@rofin-es.com
- F:** Phone +33-(0)1-6911-3636  
E-mail: info@rofin.fr
- IN:** Phone +91-(22)2761251/2/3/5  
E-mail: info@rofin.in
- IT:** Phone +39-039-2729-1  
E-mail: info@rofin.it
- JP:** Phone +81-(0)46-229-8655  
E-mail: info@rofin-baasel.co.jp
- KR:** Phone +82-(0)2-837-1750  
E-mail: info@rofin-baasel.co.kr
- SG:** Phone +65-6482-1091  
E-mail: reception@rofin-baasel.com.sg
- TW:** Phone +886-2-2790-1300  
E-mail: info@rofin-baasel.com.tw
- UK:** Phone +44-(0)1327-701-100  
E-mail: sales@rofin-baasel.co.uk
- US:** Phone: +01-734-455-5400  
E-mail: info@rofin-inc.com

Find additional service contacts on  
[www.rofin.com/worldwide](http://www.rofin.com/worldwide)